

Avantis Stylex High Performance letter plates

Contemporary design stainless steel letter plates

Manufactured from 304 grade stainless steel with an eye catching modern design, supported with state of the art surface finishing and robust construction, the Stylex range of letter plates have been designed tested to deliver years of guaranteed reliable service and stunning looks. The Stylex range also includes a suited door handle and urn knocker.

Available in Brushed and Polished Stainless steel, as well as Bright and Burnt PVD Gold finishes, with suited door handles and Stylex letter plates are fitted with brush seal as standard and are supplied with all fixings. security keeps.

Features

- ✓ 304 Stainless steel construction.
- ✓ Suitable for 44mm to 70mm door thicknesses
- ✓ Full opening sprung flaps
- ✓ Security Cowel available
- ✓ Rain-away drainage system
- ✓ FD60 compliant version available
- ✓ 10 year mechanical guarantee and surface finish guarantees

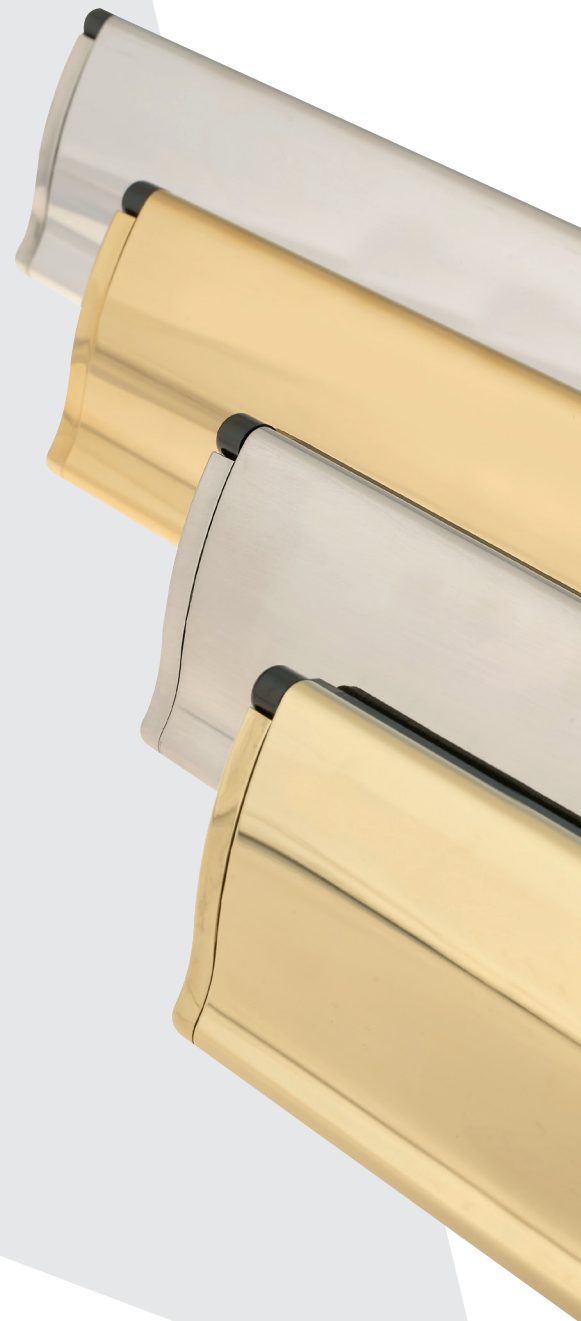

Technical specifications

- ✓ Corrosion resistance to EN1670: Grade 5 (480 hours NSS)
- ✓ Service life of 50,000 cycles
- ✓ 180° opening
- ✓ FD60 variant tested to BSEN1634-2:2008 and BSEN1361-1:1999



Part Number	Description	Description
DO1A230/BUS	Brushed Stainless Steel	20
DO1A230/S	Polished Stainless Steel	20
DO1A230/TBC	PVD Bright Gold	20
DO1A230/G	PVD Burnt Gold	20

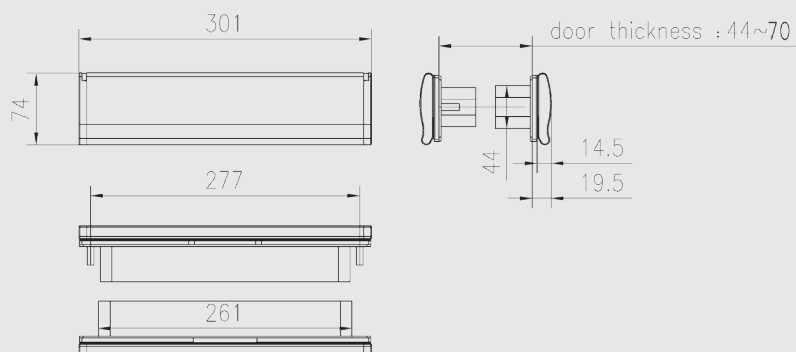

Avantis Hardware Ltd
 4th Floor Towers Business Park
 Wheelhouse Road
 Rugeley
 Staffordshire WS15 1UZ
 Tel: +44 1889 579364 Fax: +44 03300 100 502
 Website: www.avantis-international.com
 Email: sales@avantis-international.com